



Electrolux
PROFESSIONAL

**Modular Cooking Range Line
thermaline 90 - 2 Zone Full Surface
Induction Top on Closed Base, 1 Side,
Backsplash, H=800**

ITEM # _____

MODEL # _____

NAME # _____

SIS # _____

AIA # _____



589721 (MCJBFEOAA)

Free-zone Induction on closed base, 2 zones, 1-side operated with backsplash

Short Form Specification

Item No. _____

Unit constructed according to DIN 18860_2 with 20 mm drop nose top and 70 mm recessed plinth. Internal frame for heavy duty sturdiness in stainless steel. 2 mm top in 1.4301 (AISI 304). Flat surface construction, easily cleanable. THERMODUL connection system enables seamless worktop when units are connected and avoids soil penetrating. Free zone multi-coil glass ceramic surface without dead spots can host up to 8 pots&pans. Minimum cookware diameter is 7 mm. UI design to control each coil independently, power (W) and temperature settings are possible. Filters easy accessible for cleaning by user. Overheat protection switches off the supply in case of overheating. IPX5 water resistance certification. Configuration: Freestanding on closed compartment, with backsplash.

Main Features

- The free zone induction offers the possibility to use multiple pots and pans, even small sizes (min diameter 7 cm), thanks to the multi-coil system design that makes all the surface active, ideal for à la carte menu.
- The smooth glass-ceramic surface features limited temperature increase and it can be quickly and easily cleaned, thus providing maximum hygiene.
- THERMODUL connection system creates a seamless work top when units are connected to each other thus avoiding soil penetrating vital components and facilitating the removal of units in case of replacement or service.
- 360° round stepless metal knobs, working clock and anticlock wise for quick parameters selection and adjustment.
- Each zone is controlled by a touch-sensitive keypad with 7 touch buttons, 4 displays and a round knob. Each zone consists in 4 coils, which can be individually controlled or bridged in 2, 3 or 4. Power (watts) or temperature (°C) can be selected. A function is also available to set and save 3 different configurations.
- Power setting from 25 to 2000 watt in 30 steps or temperature settings from 30 to 250° C in steps of 1°C.
- Electronic sensor, placed underneath the glass, below the coil center position, to precisely measure the temperature of the pan/pot bottom
- Overheat protection: the temperature sensor switches off the supply in case of overheating.
- Heating system automatically switches off when pots and pans are removed.
- Low heat dissipation to the kitchen.

Construction

- Unit constructed according to DIN 18860_2 with 20 mm drop nose top and 70 mm recessed plinth.
- Flat surface construction with minimal hidden areas to easily clean all surfaces
- Internal frame for heavy duty sturdiness in stainless steel.
- All major components may be easily accessed from the front, including the induction filters.
- 2 mm top in 1.4301 (AISI 304).
- Closed technical base, containing generators, ventilation system and filters.
- IPX5 water resistance certification.

Sustainability

- This model is compliant with Swiss Energy Efficiency Ordinance (730.02).



APPROVAL: _____



Experience the Excellence
www.electroluxprofessional.com

Optional Accessories

- Scraper for cook tops PNC 910601
- Connecting rail kit for appliances with backsplash, 900mm PNC 912499
- Portioning shelf, 500mm width PNC 912523
- Portioning shelf, 500mm width PNC 912553
- Folding shelf, 300x900mm PNC 912581
- Folding shelf, 400x900mm PNC 912582
- Fixed side shelf, 200x900mm PNC 912589
- Fixed side shelf, 300x900mm PNC 912590
- Fixed side shelf, 400x900mm PNC 912591
- Stainless steel front kicking strip, 500mm width PNC 912595
- Stainless steel side kicking strips left and right, against the wall, 900mm width PNC 912624
- Stainless steel side kicking strips left and right, back-to-back, 1810mm width PNC 912627
- Stainless steel plinth, against wall, 500mm width PNC 912898
- Connecting rail kit for appliances with backsplash: modular 90 (on the left) to ProThermetic tilting (on the right), ProThermetic stationary (on the left) to ProThermetic tilting (on the right) PNC 912981
- Connecting rail kit for appliances with backsplash: modular 90 (on the right) to ProThermetic tilting (on the left), ProThermetic stationary (on the right) to ProThermetic tilting (on the left) PNC 912982
- Back panel, 500x800mm, for units with backsplash PNC 913023
- Stainless steel panel, 900x800mm, against wall, left side PNC 913102
- Stainless steel panel, 900x800mm, against wall, right side PNC 913106
- Endrail kit, flush-fitting, with backsplash, left PNC 913117
- Endrail kit, flush-fitting, with backsplash, right PNC 913118
- Endrail kit (12.5mm) for thermaline 90 units with backsplash, left PNC 913208
- Endrail kit (12.5mm) for thermaline 90 units with backsplash, right PNC 913209
- U-clamping rail for back-to-back installations with backsplash (to be ordered as S-code) PNC 913226
- Insert profile d=900 PNC 913232
- Side reinforced panel only in combination with side shelf, for against the wall installations, left PNC 913268
- Side reinforced panel only in combination with side shelf, for against the wall installations, right PNC 913270
- Stainless steel dividing panel, 900x800mm, (it should only be used between Electrolux Professional thermaline Modular 90 and thermaline C90) PNC 913673

- Stainless steel side panel, 900x800mm, flush-fitting (it should only be used against the wall, against a niche and in between Electrolux Professional thermaline and ProThermetic appliances and external appliances - provided that these have at least the same dimensions) PNC 913689
- Peak management system for Free-zone Induction, half module (8 coils) PNC 921026

Recommended Detergents

- C41 HI-TEMP RAPID DEGREASER, 1 pack of six 1 lt. bottles (trigger incl.) PNC 0S2292
- S01 STAINLESS STEEL SURFACE POLISHER; 6 BOTTLES X 750ML C/T PNC 0S2881
- S02 Degreaser for ovens and SpeedDelight. Specific for cleaning the cooking chambers of GourmeXpress and SpeeDelight. Active up to a maximum of 50°C Complete with spray bottle Pack of 6 750ml bottles PNC 0S2882
- S03 ALCOHOL BASE DETERGENT; 6 BOTTLES X 750ML; ADR&IMDG&IATA Limited Quantity PNC 0S2883
- S04 GLASSES & HARD SURFACES CLEANERS; 6 BOTTLES X 750ML PNC 0S2884
- S05 - MULTIPURPOSE DEGREASER; 6PCS X 750ML; ADR&IMDG Limited Quantity PNC 0S3257

Front

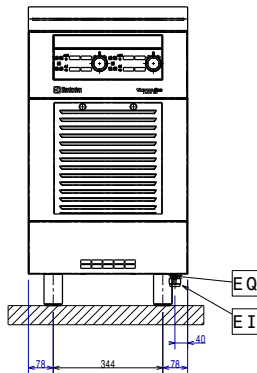

Side

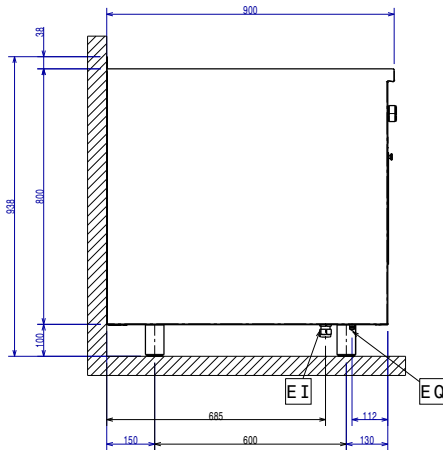

EI = Electrical inlet (power)
 EQ = Equipotential screw

Top

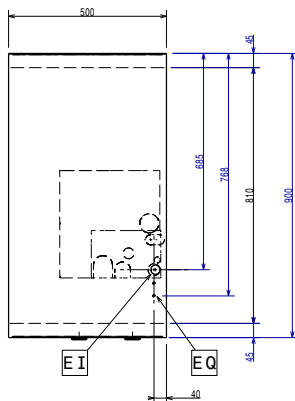

Electric

Supply voltage: 400 V/3N ph/50/60 Hz
Total Watts: 16 kW

Key Information:

External dimensions, Width: 500 mm
External dimensions, Depth: 900 mm
External dimensions, Height: 800 mm
Net weight: 52 kg

Configuration: On Base; One-Side Operated

Front Plates Power: 8 - 0 kW

Back Plates Power: 8 - kW

Front Plates dimensions: 320x320

Back Plates dimensions: 320x320

Induction Top Dimensions (width): 500 mm

Induction Top Dimensions (depth): 900 mm

Sustainability

Current consumption: 21.5 Amps